

Technical Data Sheet

Shower Systems

TAVISTOCK

No.	Description	Code	Fixings Included
1	Cheltenham 2F Exposed Shower System	SCM1713	YES



Inlet Pressure	Flow Rate (l/min)
1bar	10.29
2bar	13.98
3bar	17.34
4bar	19.98
5bar	22.56

Dimensions - Overview

Diagrams not to scale. All dimensions in mm (tolerance of +/-5mm)

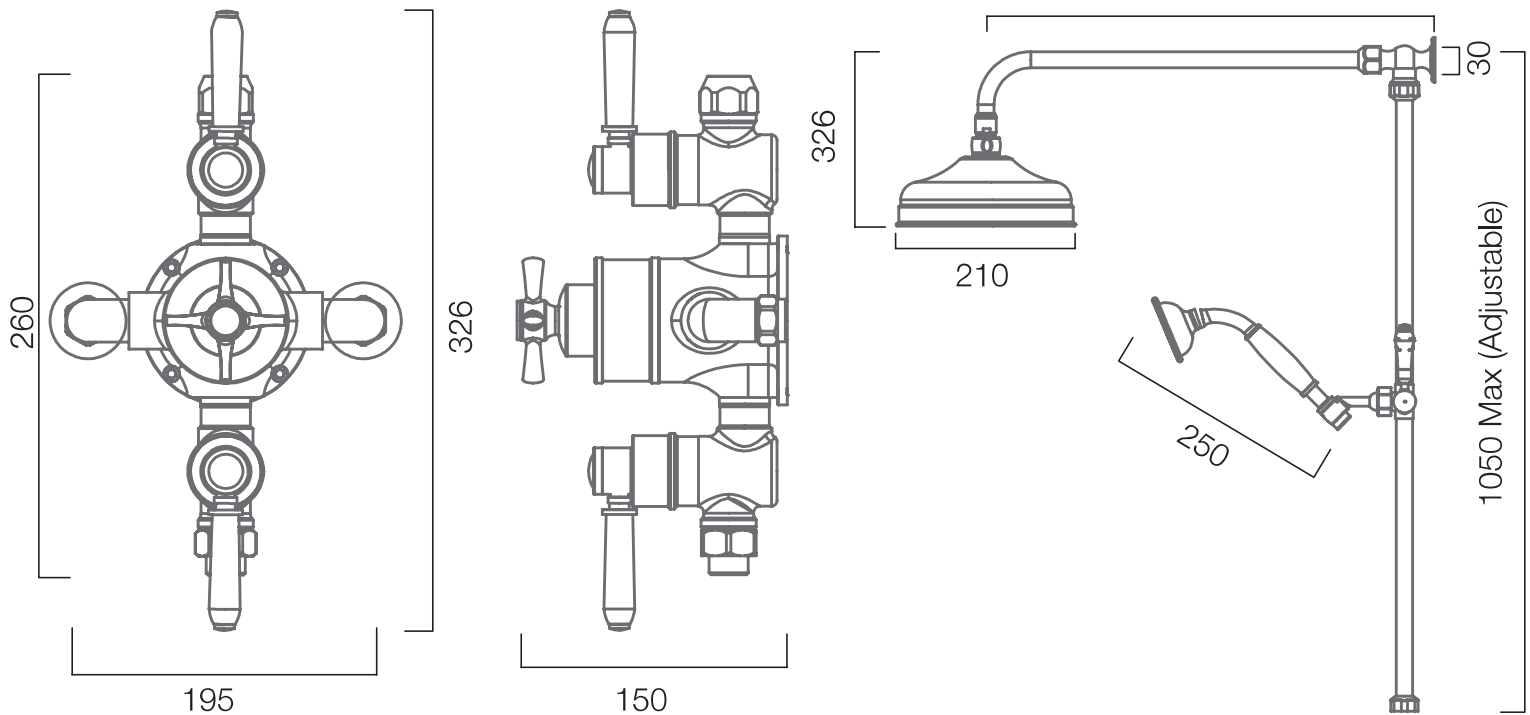

FAQs

How tall is the riser rail? 1000mm

How long is the shower hose? 1.5m

What is the minimum pressure for the valve? 1.0bar

What is the valve connection size? 1/2" suitable for 15mm pipework