

Edition 11

11153019000 Double holder

PRODUCT



DRAWING

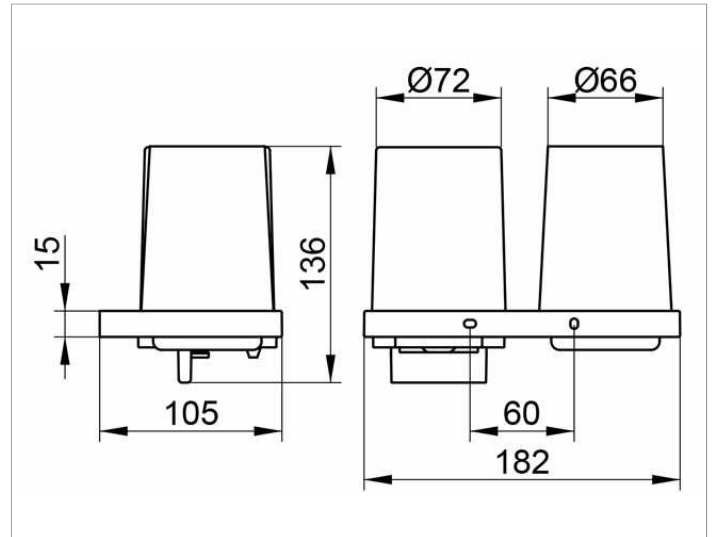

PRODUCT ATTRIBUTES

complete, comes with:
 1 x glass, hand-blown
 1 x lotiondispenser
 complete with matt glass and pump for liquid soap
 Capacity: approx. 180 ml
 Dosage: approx. 0,5 ml/stroke

SURFACE

chrome-plated

SPECIFICATIONS

KEUCO EDITION 11 double holder 11153019000 for wall mounting, complete
 chromed twin bracket consisting of:
 1 x crystal glass tumbler and lotion dispenser 1x dash; complete with frosted crystal glass and pump fluid into rectilinear geometric shape design and clear language, easy to clean
 Height 136 mm, width 182 mm, 105 mm
 delivery with corrosion resistant mounting hardware